



# Typhoon Mach 3

## 316 Stainless Steel 48"/52"/56"

- 3 SPEED WALL CONTROL
- LIGHT ADAPTABLE
- REMOTE ADAPTABLE
- REVERSIBLE
- 19° BLADE PITCH
- 7 YEAR WARRANTY



### 316 STAINLESS STEEL

With stainless steel blades

A3402 - 1220mm (48")

A3412 - 1320mm (52")

A3422 - 1420mm (56")

^Please refer to website terms & conditions

# Typhoon Mach 3 316 Stainless Steel 48"/52"/56"

## Product Range:

316 Stainless Steel with Stainless Steel Blades  
 A3402 - 1220mm (48")  
 A3412 - 1320mm (52")  
 A3422 - 1420mm (56")

## Features:

- 3 Speed wall controller
- Summer/Winter reversible via switch on motor
- Light Adaptable
- Remote Adaptable
- Suitable for pitched ceilings up to 32°
- 7 Year warranty

## Installation Locations:

White: Indoor Only  
 316 Stainless Steel: Indoor, coastal and outdoor undercover (provided the fan is fully undercover).

## Wall Controller Speed Capacitor Values:

2.5µF & 4.5µF

## Warranty:

- 3 year in-home warranty on the motor, excluding cosmetic issues and corrosion (unless reported in the first 3 months).
- 4 year additional Parts Only Warranty on the motor.
- All non-integrated HPI light kits and AC remote control systems are separately purchased accessories for AC ceiling fans, and as such are covered by our accessory parts warranty.
- 1 year warranty applies when the fan or relevant part is used in any non-domestic applications.

\*For full warranty details please see Hunter Pacific International's website [www.hunterpacific.com.au](http://www.hunterpacific.com.au)

## Accessories (Supplied separately):

### Down Rod 21mm diameter (includes wire loom)

059 - 91cm 316 Stainless Steel Downrod  
 068 - 150cm 316 Stainless Steel Downrod  
 009 - T-Hook for ceiling roses

### AC Remote Control Units

A2002 - Konetik (3 speed - non dimming AC remote)  
 A2003 - Logic (4 speed - dimming AC remote)

### Light Kit (lamps not included)

A3484 - Eclipse 316 Stainless Steel 2 x E27 Light

### Zellweger Ripple Tone Filter Unit

007 ZF-1050 Notch Filter Noise Suppressor  
 008 ZF-750 Notch Filter Noise Suppressor

### W06-018 Wall Mech & Knob Only

W06-028 Start Run Capacitor 2.2uF

## Extra Information:

**Motor:** 194mm x 14mm motor 16 Pole  
 Made with the highest grade copper windings and silicone steel stator. Bearings are sealed to ensure quiet operation and long life.

### Blades:

1220mm (48"), 1320mm (52"), 1420mm (56")  
 Materials: 316 Stainless Steel or White Aluminium painted blades  
 Blade Pitch: 19°

## Packaging Dimensions (cm):

Complete fan:  
 (48"): 62L x 23W x 27H  
 (52"): 62L x 23W x 27H  
 (56"): 71L x 23W x 27H

## Weight Including Packaging:

Complete fan: 8kg (48" & 52") / 9kg (56")

|               | 1220mm (48") |        |       | 1320mm (52") |        |       | 1420mm (56") |        |       |
|---------------|--------------|--------|-------|--------------|--------|-------|--------------|--------|-------|
|               | LOW          | MEDIUM | HIGH  | LOW          | MEDIUM | HIGH  | LOW          | MEDIUM | HIGH  |
| RPMS          | 102          | 189    | 258   | 98           | 154    | 208   | 94           | 164    | 220   |
| WATTS         | 14.0         | 29.9   | 64.1  | 14.0         | 30.0   | 64.0  | 18.0         | 34.0   | 72.8  |
| AIRFLOW (CMH) | 5627         | 8948   | 13824 | 7239         | 11137  | 16345 | 7941         | 12498  | 18512 |

\* CMH = Cubic Meters per Hour

## DIMENSIONS

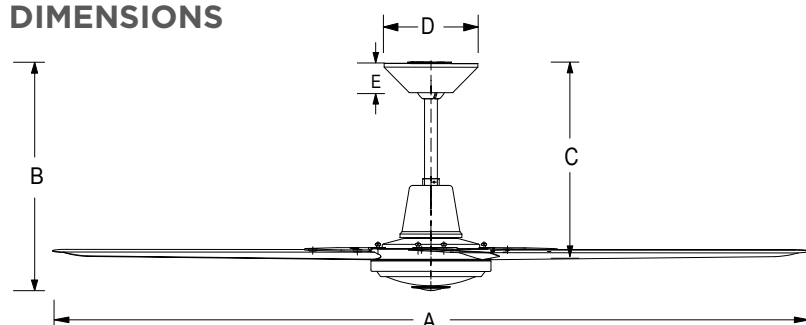

|   | 1220mm (48") | 1320mm (52") | 1420mm (56") |
|---|--------------|--------------|--------------|
| A | 1220mm       | 1320mm       | 1420mm       |
| B | 370mm        | 370mm        | 370mm        |
| C | 320mm        | 320mm        | 320mm        |
| D | 153mm        | 153mm        | 153mm        |
| E | 48mm         | 48mm         | 48mm         |