



X-Over 52" with Light

- 3 SPEED WALL CONTROL
- 10.7° BLADE PITCH
- REVERSIBLE
- 7 YEAR WARRANTY



XOL306
WHITE
With white polymer blades
1320mm (52")

X-Over 52" with Light

Product Range:

XOL306 - White with White Blades

Features:

- Quick Connect Blade System
- 3 Speed Wall Control including RF MCU Unit
- Energy efficient and quiet DC motor
- Summer/Winter reversible via switch on motor
- ABS polymer UV stabilised blades
- Non Remote Adaptable
- 18W dimmable CCT LED light (requires dimmer)
- Suitable for pitched ceilings up to 28°
- 7 Year warranty

Installation Locations:

Coastal, indoor and outdoor locations. The fan is also suitable for installation in a pergola or outside in a sheltered area, protected from wind and rain.

There should be at least 2.1m between the lowest point of the fan blades and the floor.

Warranty:

- 3 year in-home warranty on the motor, excluding cosmetic issues and corrosion (unless reported in the first 3 months).
- 4 year additional Parts Only Warranty on the motor.
- 2 year in-home warranty on all DC electronic components such as DC remote control systems, lighting and Accessory Wall Control.
- 1 year warranty applies when the fan or relevant part is used in any non-domestic applications.

*For full warranty details please see Hunter Pacific International's website www.hunterpacific.com.au

Accessories (Supplied separately):

Down Rod 26mm diameter (includes wire loom)

- 010 - 91cm White Downrod
- 020 - 180cm White Downrod

38° Ceiling Kit (for pitched ceilings)

- 080 - Ceiling Kit White
- 009 - T-Hook for ceiling roses

- DCS260 - Wall Mech and Magic Box to suit X-Over only
- DCR248 - DC Receiver & Smart Switch X-Over 52"
- W06-018 - Wall Mech and knob only

Light Fitting:

18W CCT LED light (dimmable)
 Colour Temperatures: 3000 K, 4000 K, 6000 K
 Output (lm): 1842 / 2370 / 2123

Extra Information:

Motor: 125mm x 13mm DC motor
 Made with high grade copper windings and silicone steel stator. Bearings are sealed to ensure quiet operation and long life.

Blades: 1320mm (52")
 Materials: ABS polymer UV stabilised
 Blade Pitch: 10.7°

Weight Including Packaging:

Complete fan: 6.7kg

Packaging Dimensions (cm):

Complete Fan: 62.6L x 29W x 31.5H

	Low	Medium	High
RPMS	78	143	190
WATTS	3.0	10.8	25.1
AIRFLOW (CMH)	4828	12001	13852

* CMH = Cubic Meters per Hour

DIMENSIONS

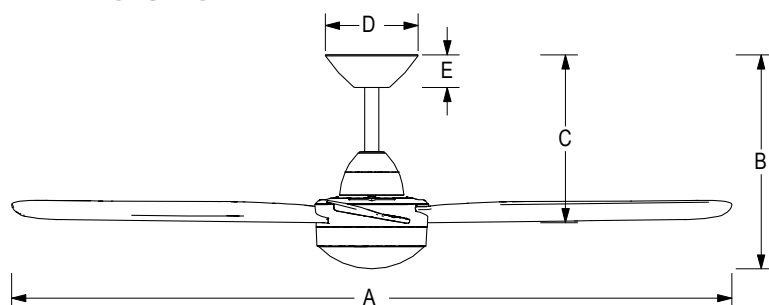

A	1320mm
B	396mm
C	300mm
D	170mm
E	60mm