



Azure Moulded 48" with 2xE27 Light

3 SPEED
WALL
CONTROL

REMOTE
ADAPTABLE

REVERSIBLE

10°
BLADE
PITCH

7 YEAR
WARRANTY



A225

WHITE

With white moulded blades
1220mm (48")

[^]Please refer to website terms & conditions

Azure Moulded 48" with 2xE27 Light

Product Range:

A225 - White with White Blades 2xE27 Light Kit

Features:

- 3 Speed wall controller
- Summer/Winter reversible via switch on motor
- Moulded plastic blades
- Remote Adaptable
- Suitable for pitched ceilings up to 28°
- 7 Year warranty

Installation Locations:

Indoor installation only.

There should be at least 2.1m between the lowest point of the fan blades and the floor.

Wall Controller Speed Capacitor Values:

3.5µF & 2µF

Warranty:

- 3 year in-home warranty on the motor, excluding cosmetic issues and corrosion (unless reported in the first 3 months).
- 4 year additional Parts Only Warranty on the motor.
- All non-integrated HPI light kits and AC remote control systems are separately purchased accessories for AC ceiling fans, and as such are covered by our accessory parts warranty.
- 1 year warranty applies when the fan or relevant part is used in any non-domestic applications.

*For full warranty details please see Hunter Pacific International's website www.hunterpacific.com.au

Accessories (Supplied separately):

Down Rod 21mm diameter (includes wire loom)

- 050 - 91cm White Downrod
- 060 - 180cm White Downrod

009 - T-Hook for ceiling roses

AC Remote Control Units

- A2002 - Konetik (3 speed - non dimming AC remote)
- A2003 - Logic (4 speed - dimming AC remote)

Zellweger Ripple Tone Filter Unit

- 007 - ZF-1050 Notch Filter Noise Suppressor
- 008 - ZF-750 Notch Filter Noise Suppressor

W04-504 Replacement Diffuser Only

W06-015 Capacitor 2 & 3.5uF

W06-018 Wall Mech & Knob Only

W06-023 Start Run Cap 1.8uF

W06-026 Wall Mech & Capacitor 2 & 3.5uF

Available integrated light options:

2x E27 screw sockets (bulbs not supplied)

Extra Information:

Motor: 153mm x 15mm motor 16 Pole
Made with the highest grade copper windings and silicone steel stator. Bearings are sealed to ensure quiet operation and long life.

Blades: 1220mm (48") Straight Style
Materials: Moulded plastic
Blade Pitch: 10°

Weight Including Packaging:

Complete fan: 8.1kg

Packaging Dimensions (cm):

54.3L x 25.3W x 27.5H

	Low	Medium	High
RPMS	102	145	182
WATTS	16.9	36.3	64.0
AIRFLOW: CMH*	6459	8637	11542

* CMH = Cubic Meters per Hour

DIMENSIONS

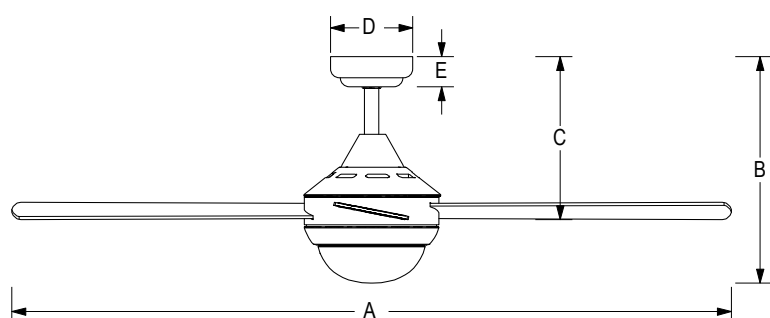

A	1220mm
B	419mm
C	316mm
D	131mm
E	57mm